

4BLOCK

4" monoblock submersible pumps



-  Clean water
(Maximum sand content 150 g/m³)
-  Domestic use
-  Civil use
-  Agricultural use

PERFORMANCE RANGE

- Flow rate up to **150 l/min** (9 m³/h)
- Head up to **128 m**

APPLICATION LIMITS

- Maximum liquid temperature **+35 °C**
- Maximum sand content **150 g/m³**
- Maximum immersion depth of **60 m** with a sufficiently long power cable
- Vertical and horizontal installation
- Starts/hour: **20** at regular intervals
- Continuous service **S1**

CONSTRUCTION AND SAFETY STANDARDS

EN 60335-1
IEC 60335-1
CEI 61-150

EN 60034-1
IEC 60034-1
CEI 2-3



EU REGULATION N. 547/2012

CERTIFICATIONS

Company with management system certified DNV
ISO 9001: QUALITY
ISO 14001: ENVIRONMENT



INSTALLATION AND USE

Suitable for pumping clean water from boreholes that contain sand (up to 150 g/m³).

Because of their high efficiency and reliability they are suitable for use in domestic applications such as domestic water supply as part of a pressure supply and for irrigation, etc.

PATENTS - TRADE MARKS - MODELS

- Patent Pending n. PCT/IB2009/051491
- Patent Pending n. PCT/IB2010/054499
- Patent n. EP09781276.2

OPTIONS AVAILABLE ON REQUEST

- **30 metres** long power cable
- Other voltages or 60 Hz frequency

► Ready to install, stainless steel monoblock submersible pump.

Complete with: – motor with built-in capacitor and thermal overload protector
– 20 m long power cable.

CHARACTERISTIC CURVES AND PERFORMANCE DATA

50 Hz n = 2900 rpm

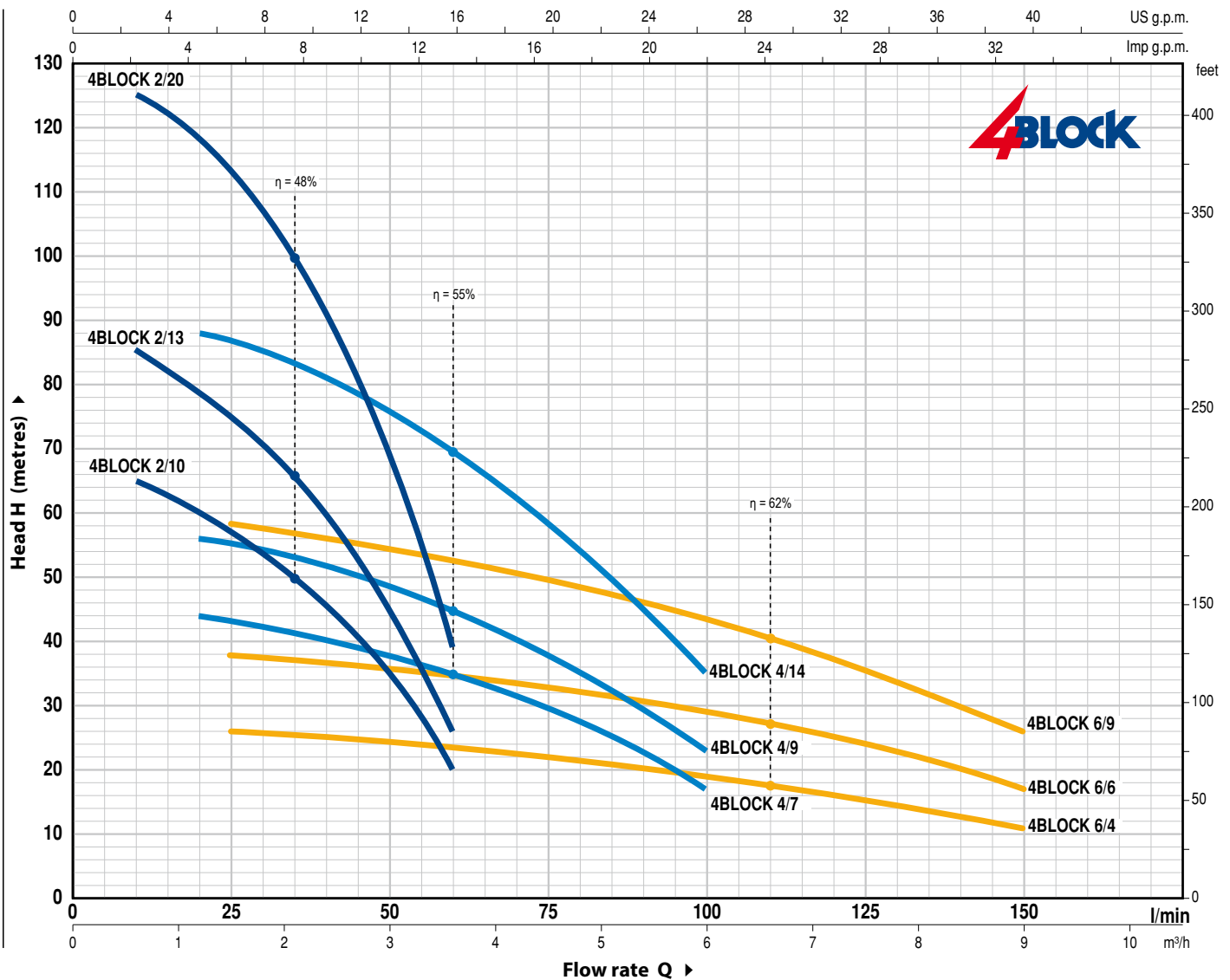

MODEL	POWER (P ₂)		Q	Flow rate							
	kW	HP		m ³ /h	0	0.6	1.2	1.8	2.4	3.0	3.6
Single-phase			Q	0	10	20	30	40	50	60	
4BLOCKm 2/10	0.55	0.75	H metres	66	65	60	54	46	35	20	
4BLOCKm 2/13	0.75	1	H metres	86	85	79	71	60	45	26	
4BLOCKm 2/20	1.1	1.5	H metres	128	125	118	108	91	70	39	

MODEL	POWER (P ₂)		Q	Flow rate										
	kW	HP		m ³ /h	0	1.2	1.8	2.4	3.0	3.6	4.2	4.8	5.4	6.0
Single-phase			Q	0	20	30	40	50	60	70	80	90	100	
4BLOCKm 4/7	0.55	0.75	H metres	46	44	42	40	38	35	31.5	27	23	17	
4BLOCKm 4/9	0.75	1	H metres	60	56	54.5	52	49	45	40.5	35	29	23	
4BLOCKm 4/14	1.1	1.5	H metres	92	88	85	81	76	70	63	54.5	45	35	

MODEL	POWER (P ₂)		Q	Flow rate						
	kW	HP		m ³ /h	0	1.5	3.0	4.5	6.0	7.5
Single-phase			Q	0	25	50	75	100	125	150
4BLOCKm 6/4	0.55	0.75	H metres	27	26	24	22	19	15	11
4BLOCKm 6/6	0.75	1	H metres	40	38	36	33	29	24	17
4BLOCKm 6/9	1.1	1.5	H metres	61	58	54	50	44	35	26

Q = Flow rate H = Total manometric head

Tolerance of characteristic curves in compliance with EN ISO 9906 Grade 3B.

4BLOCK

POS. COMPONENT CONSTRUCTION CHARACTERISTICS

1	DELIVERY BODY AND EXTERNAL SLEEVE	Stainless steel AISI 304 complete with threaded delivery port in compliance with ISO 228/1.
2	IMPELLERS	Lexan 141-R
3	DIFFUSERS	Noryl FE1520PW
4	STAGE CASING	Stainless steel AISI 304
5	PUMP SHAFT	Stainless steel AISI 304
6	PUMP BEARINGS	Special technopolymer housing with stainless steel AISI 316, chrome oxide coated, sand resistant shaft bushing.
7	DRIVE COUPLING	Stainless steel AISI 316L
8	CABLE COVER	Stainless steel AISI 304
9	MOTOR SHAFT	Stainless steel EN 10088-3 1.4104 (AISI 431 per 1.1 kW single-phase)
10	MOTOR SLEEVE	Stainless steel AISI 304

11 TWO MECHANICAL SEALS SEPARATED BY AN OIL CHAMBER

Seal	Shaft	Position	Materials		
Model	Diameter		Stationary ring	Rotational ring	Elastomer
STA-17	Ø 17 mm	Motor side	Ceramic	Graphite	NBR
ST1-16	Ø 16 mm	Pump side	Silicon carbide	Graphite	NBR

12 BEARINGS

Pump	Model
4BLOCK – 0.55÷0.75 kW	6203 2RS - C3E / 6203 ZZ - C3E
4BLOCK – 1.1 kW	3203B 2RS - C3 / 6203 ZZ - C3E

13 CAPACITOR

Pump	Capacitance
Single-phase	(230 V or 240 V)
4BLOCK – 0.55 kW	20 µF - 500 VL
4BLOCK – 0.75 kW	31.5 µF - 500 VL
4BLOCK – 1.1 kW	35 µF - 500 VL

14 ELECTRIC MOTOR

Submersible PEDROLLO motor, suitable for continuous duty (with dry, rewindable stator).

4BLOCKm: single-phase 230 V - 50 Hz
Motor with built-in capacitor.
Thermal overload protector incorporated into the winding.

- Insulation: class F
- Protection: IP X8

15 POWER CABLE

⇒ **PBS-P type**
approved for use in drinking water by "ACS"
in compliance with BS 6920, approval n. 04 ACCLI 201
Standard length 20 metres

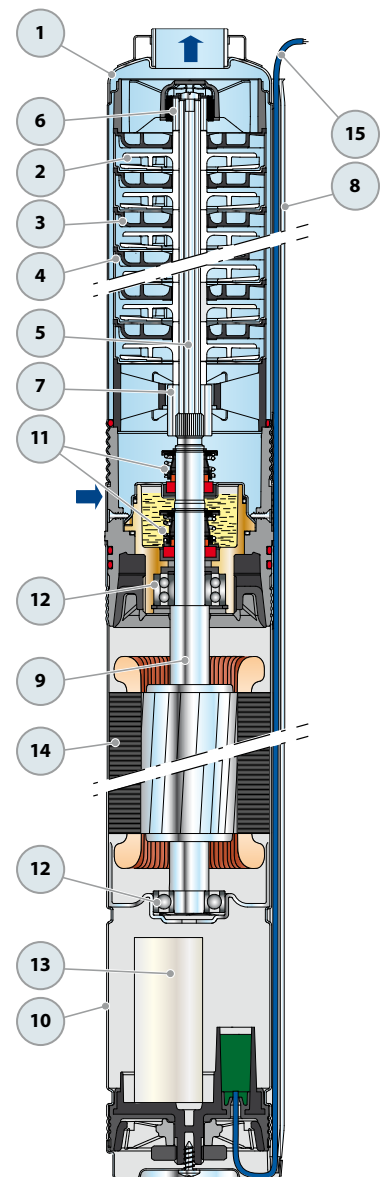

DIMENSIONS AND WEIGHT

MODEL	PORT DN	DIMENSIONS mm			kg
		N. STAGES	Ø	h	
Single-phase					1~
4BLOCKm 2/10	1¼"	10	100	705	12.5
4BLOCKm 2/13		13		786	14.3
4BLOCKm 2/20		20		986	17.8
4BLOCKm 4/7		7		674	12.1
4BLOCKm 4/9		9		743	13.8
4BLOCKm 4/14		14		925	17.0
4BLOCKm 6/4		4		641	10.7
4BLOCKm 6/6		6		725	13.3
4BLOCKm 6/9		9		887	16.5

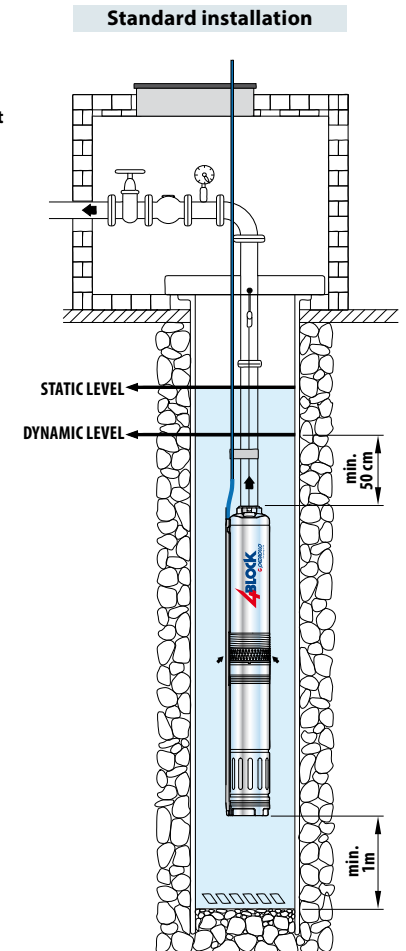
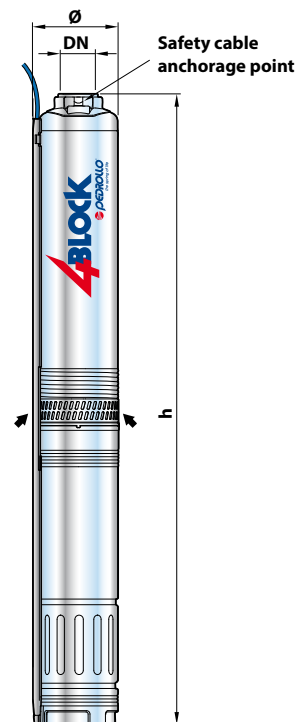

ABSORPTION

MODEL	VOLTAGE	
	230 V	240 V
Single-phase		
4BLOCKm – 0.55 kW	5.0 A	4.8 A
4BLOCKm – 0.75 kW	6.0 A	5.8 A
4BLOCKm – 1.1 kW	8.0 A	7.8 A

PALLETIZATION

MODEL	GROUPAGE/CONTAINER
Single-phase	
4BLOCKm 2/10	55
4BLOCKm 2/13	33
4BLOCKm 2/20	33
4BLOCKm 4/7	55
4BLOCKm 4/9	55
4BLOCKm 4/14	33
4BLOCKm 6/4	55
4BLOCKm 6/6	55
4BLOCKm 6/9	33